



Test Report issued under the responsibility of:



<b>TEST REPORT</b> <b>IEC 62619</b> <b>Secondary cells and batteries containing alkaline or other non-acid electrolytes - Safety requirements for secondary lithium cells and batteries, for use in industrial applications</b>	
<b>Report Number</b> ..... :	RESS-4788914086-002
<b>Date of issue</b> ..... :	2019-04-11
<b>Total number of pages</b> .....	19
<b>Name of Testing Laboratory preparing the Report</b> .....	Shanghai Truron Testing Technology Co., Ltd
<b>Applicant's name</b> .....	Hefei Guoxuan High-Tech Power Energy Co., Ltd
<b>Address</b> ..... :	No 599 Daihe Road Xinzhan District Hefei, Anhui 230011,China
<b>Test specification:</b>	
<b>Standard</b> .....	IEC 62619: 2017
<b>Test procedure</b> .....	CB Scheme
<b>Non-standard test method</b> .....	N/A
<b>Test Report Form No.</b> .....	IE62619A
<b>Test Report Form(s) Originator</b> .... :	UL(Demko)
<b>Master TRF</b> .....	Dated 2018-06-07
<b>Copyright © 2018 IEC System of Conformity Assessment Schemes for Electrotechnical Equipment and Components (IECEE System). All rights reserved.</b>	
This publication may be reproduced in whole or in part for non-commercial purposes as long as the IECEE is acknowledged as copyright owner and source of the material. IECEE takes no responsibility for and will not assume liability for damages resulting from the reader's interpretation of the reproduced material due to its placement and context.	
If this Test Report Form is used by non-IECEE members, the IECEE/IEC logo and the reference to the CB Scheme procedure shall be removed.	
<b>This report is not valid as a CB Test Report unless signed by an approved CB Testing Laboratory and appended to a CB Test Certificate issued by an NCB in accordance with IECEE 02.</b>	
<b>General disclaimer:</b>	
The test results presented in this report relate only to the object tested. This report shall not be reproduced, except in full, without the written approval of the Issuing CB Testing Laboratory. The authenticity of this Test Report and its contents can be verified by contacting the NCB, responsible for this Test Report.	

<b>Test item description</b> .....	Rechargeable Lithium-ion Cell	
<b>Trade Mark</b> .....	N/A	
<b>Manufacturer</b> .....	Hefei Guoxuan High-Tech Power Energy Co., Ltd No 599 Daihe Road Xinzhan District Hefei, Anhui 230011,China	
<b>Model/Type reference</b> .....	IFP20100140A-27Ah	
<b>Ratings</b> .....	27Ah, 3.2Vdc, 86.4Wh	
<b>Responsible Testing Laboratory (as applicable), testing procedure and testing location(s):</b>		
<input checked="" type="checkbox"/>	<b>CB Testing Laboratory:</b>	Shanghai Truron Testing Technology Co., Ltd.
<b>Testing location/ address</b> .....		Floor 1 and 2, Building 1, No. 685, Huishan Road, Shanghai, China
<b>Tested by (name, function, signature) .....</b>		(Project Handler) Velvet Cao <i>Velvet Cao</i>
<b>Approved by (name, function, signature) ..</b>		(Reviewer) Sally Ren <i>Sally Ren</i>
<input type="checkbox"/>	<b>Testing procedure: CTF Stage 1:</b>	
<b>Testing location/ address</b> .....		
<b>Tested by (name, function, signature) .....</b>		
<b>Approved by (name, function, signature) ..</b>		
<input type="checkbox"/>	<b>Testing procedure: CTF Stage 2:</b>	
<b>Testing location/ address</b> .....		
<b>Tested by (name + signature).....</b>		
<b>Witnessed by (name, function, signature) . :</b>		
<b>Approved by (name, function, signature) .. :</b>		
<input type="checkbox"/>	<b>Testing procedure: CTF Stage 3:</b>	
<input type="checkbox"/>	<b>Testing procedure: CTF Stage 4:</b>	
<b>Testing location/ address</b> .....		
<b>Tested by (name, function, signature) .....</b>		
<b>Witnessed by (name, function, signature) . :</b>		
<b>Approved by (name, function, signature) .. :</b>		
<b>Supervised by (name, function, signature) :</b>		

<p><b>List of Attachments (including a total number of pages in each attachment):</b>  National Differences ( 0 pages)  Enclosures (10 pages)</p>	
<p><b>Summary of testing:</b></p>	
<p><b>Tests performed (name of test and test clause):</b></p> <p>Cell IFP20100140A-27Ah  Original Test:  7.2.1 External short-circuit test (cell)  7.2.2 Impact test (cell)  7.2.3.2 Whole drop test (cell)  7.2.4 Thermal abuse test (cell)  7.2.5 Overcharge test (cell)  7.2.6 Forced discharge test (cell)  7.3.2 Internal Short-circuit test(cell)  Reissue Test:  7.2.6 Forced discharge test (cell)  7.3.2 Internal Short-circuit test(cell)</p>	<p><b>Testing location:</b></p> <p>Shanghai Truron Testing Technology Co., Ltd.   Floor 1 and 2, Building 1, No. 685, Huishan Road,  Shanghai, China</p>
<p><b>Summary of compliance with National Differences (List of countries addressed):N/A</b></p> <p><input checked="" type="checkbox"/> <b>The product fulfils the requirements of EN 62619:2017</b></p>	

**Copy of marking plate:**

**The artwork below may be only a draft. The use of certification marks on a product must be authorized by the respective NCBs that own these marks.**

Marking

+	-
Manufacturer: Hefei Guoxuan High-tech Power Energy Co., Ltd	
Product name: Rechargeable Lithium-ion Cell	
Product model: IFP20100140A-27Ah	
Power rating: 3.2V, 27Ah, 86.4Wh	
Date of manufacture: YYM	
IFpP21/101/141/M/-30+30/90	

<b>Test item particulars</b> .....	
<b>Classification of installation and use</b> ..... For built-in	
<b>Supply Connection</b> ..... N/A .....	
<b>Possible test case verdicts:</b> - test case does not apply to the test object ..... N/A - test object does meet the requirement ..... P (Pass) - test object does not meet the requirement ..... F (Fail)	
<b>Testing</b> .....	
<b>Date of receipt of test item</b> ..... 2019-03-01	
<b>Date (s) of performance of tests</b> ..... 2019-03-01 to 2019-03-06	
<b>General remarks:</b>	
"(See Enclosure #)" refers to additional information appended to the report. "(See appended table)" refers to a table appended to the report.	
Throughout this report a <input type="checkbox"/> comma / <input checked="" type="checkbox"/> point is used as the decimal separator.	
<b>Manufacturer's Declaration per sub-clause 4.2.5 of IEC60080-02:</b>	
The application for obtaining a CB Test Certificate includes more than one factory location and a declaration from the Manufacturer stating that the sample(s) submitted for evaluation is (are) representative of the products from each factory has been provided.....	<input type="checkbox"/> Yes <input checked="" type="checkbox"/> Not applicable
<b>When differences exist; they shall be identified in the General product information section.</b>	
<b>Name and address of factory (ies)</b> ..... Hefei Guoxuan High-Tech Power Energy Co.,Ltd  No 599 Daihe Road Xinzhan District Hefei, Anhui 230011,China	
<b>General product information and other remarks:</b>	
-- Rechargeable Lithium Ion Phosphate Prismatic cell, all positive electrode, negative electrode and separator are covered by Al case and insulation materials. - Maximum charge current/voltage of 54A/3.9V, end of discharging voltage is 2.0V - Upper limit charging voltage is 3.85V - IFpP21/101/141/M/-30+30/90 is identical to model IFP20100140A-27Ah except for model designation.	

**Technical Reissue :**

This report is a reissue of CBTR Ref. No. RESS-4788659356-A01-01, Issued Date:2018-11-27; CB Test Certificate Ref. No. DK-78638-UL, Issued Date: 2018-11-29. Based on previously conducted testing and the review of product construction, Forced discharge test and Internal Short-circuit test were deemed necessary.

This test report was deemed to reissue, due to : Chang cell maximum charging voltage , maximum discharging current, upper limit charging voltage and maximum charge temperature due to customer's requirement.

Below tests were conducted:

7.2.6 Forced discharge test (cell)

7.3.2 Internal Short-circuit test(cell)

IEC 62619			
Clause	Requirement + Test	Result - Remark	Verdict
<b>4</b>	<b>PARAMETER MEASUREMENT TOLERANCES</b>		<b>P</b>
	Parameter measurement tolerances		P
<b>5</b>	<b>GENERAL SAFETY CONSIDERATIONS</b>		<b>P</b>
<b>5.1</b>	<b>General</b>		<b>P</b>
	Cells and batteries are safe under conditions of both intended use and reasonably foreseeable misuse...		P
<b>5.2</b>	<b>Insulation and wiring</b>		N/A
	Voltage, current, altitude, and humidity requirements		N/A
	Adequate clearances and creepage distances between connectors		N/A
	The mechanical integrity of internal connections		N/A
<b>5.3</b>	<b>Venting</b>		<b>P</b>
	Pressure relief function		P
	Encapsulation used to support cells within an outer casing		N/A
<b>5.4</b>	<b>Temperature/voltage/current management</b>		N/A
	The design prevents abnormal temperature-rise		N/A
	Voltage, current, and temperature limits of the cells		N/A
	Specifications and charging instructions for equipment manufacturers		N/A
<b>5.5</b>	<b>Terminal contacts of the battery pack and/or battery system</b>		N/A
	Polarity marking(s)		N/A
	Capability to carry the maximum anticipated current		N/A
	External terminal contact surfaces		N/A
	Terminal contacts are arranged to minimize the risk of short circuits		N/A
<b>5.6</b>	<b>Assembly of cells, modules, or battery packs into battery systems</b>		N/A
5.6.1	<b>General</b>		N/A
	Independent control and protection method(s)		N/A
	Recommendations of cell operating limits by the cell manufacturer		N/A
	Batteries designed for the selective discharge of a portion of their series connected cells		N/A
	Protective circuit component(s) and consideration to the end-device application		N/A

IEC 62619			
Clause	Requirement + Test	Result - Remark	Verdict
5.6.2	Battery system design		N/A
	The voltage control function		N/A
	The voltage control for series-connected batteries		N/A
<b>5.7</b>	<b>Operating region of lithium cells and battery systems for safe use</b>		<b>P</b>
	The cell operating region..... :	Upper limit charge voltage: 3.85V; Cut off discharge Voltage: 2.0V	P
	Designation of battery system to comply with the cell operating region		N/A
<b>5.8</b>	<b>Quality plan</b>		<b>P</b>
	Manufacturing quality plan (for example: ISO9001, etc.) prepared and implemented..... :	Reference: The manufacturer has IATF 16949 certification, see enclosure ID 6	P
	The process capabilities and the process controls		P
<b>6</b>	<b>TYPE TEST CONDITIONS</b>		<b>P</b>
<b>6.1</b>	<b>General</b>		<b>P</b>
<b>6.2</b>	<b>Test items</b>		<b>P</b>
	Cells or batteries that are not more than six months old (See Table 1 of IEC62619)		P
	Capacity confirmation of the cells or batteries		P
	Default ambient temperature of test, 25 °C ± 5 °C		P
<b>7</b>	<b>SPECIFIC REQUIREMENTS AND TESTS</b>		<b>P</b>
<b>7.1</b>	<b>Charging procedure for test purposes</b>		<b>P</b>
	The battery discharged to a specified final voltage prior to charging		N/A
	The cells or batteries charged using the method specified by the manufacturer..... :	Cell: CC/CV 27A at 3.65V;	P
<b>7.2</b>	<b>Reasonably foreseeable misuse</b>		<b>P</b>
7.2.1	External short-circuit test (cell or cell block)		P
	Short circuit with total resistance of 30 mΩ ± 10 mΩ at 25 °C ± 5 °C		P
	Results: no fire, no explosion		P
7.2.2	Impact test (cell or cell block)		P
	Cylindrical cell, longitudinal axis impact		N/A



IEC 62619			
Clause	Requirement + Test	Result - Remark	Verdict
	Prismatic cell, longitudinal axis and lateral axis impact		P
	Results: no fire, no explosion.		P
7.2.3	Drop test (cell or cell block, and battery system)		P
7.2.3.1	General		P
7.2.3.2	Whole drop test (cell or cell block, and battery system)		P
	Description of the Test Unit..... :	Cell	—
	Mass of the test unit (kg)..... :	Cell: 0.610	—
	Height of drop (m)..... :	1	—
	Results: no fire, no explosion		P
7.2.3.3	Edge and corner drop test (cell or cell block, and battery system)		N/A
	Description of the Test Unit..... :		—
	Mass of the test unit (kg)..... :		—
	Height of drop (m)..... :		—
	Results: no fire, no explosion		N/A
7.2.4	Thermal abuse test (cell or cell block)		P
	Results: no fire, no explosion		P
7.2.5	Overcharge test (cell or cell block)		P
	For the modules that are provided with none protection for the charging voltage control		—
	Results: no fire, no explosion..... :	See Table 7.2.5.	P
7.2.6	Forced discharge test (cell or cell block)		P
	Upper limit charge voltage of the cell..... :	3.85V	—
	Cells connected in series in the battery system .....	Single cell	—
	Redundant or single protection for discharge voltage control provided in Module .....	N/A	—
	Target Voltage .....	-3.85V	—
	Maximum discharge current of the cell, $I_m$ ..... :	67.5A	—
	Discharge current for forced discharge, 1.0 It .....	27A	—
	Discharging time, $t = (1 It / I_m) \times 90$ (min.) .....	90min	—
	Results: no fire, no explosion..... :	See Table 7.2.6.	P
<b>7.3</b>	<b>Considerations for internal short-circuit – Design evaluation</b>		P
7.3.1	General		P
7.3.2	Internal short-circuit test (cell)		P

IEC 62619			
Clause	Requirement + Test	Result - Remark	Verdict
	Samples preparation procedure: a), in accordance with 8.3.9 of IEC62133:2012; or b), the nickel particle inserted before charging, or c), the nickel particle was inserted before electrolyte filling .....	a)	P
	Tested according to Cl. 8.3.9 of IEC 62133:2012 test method, except all tests were carried out in an ambient temperature of 25 °C ± 5 °C.		P
	The appearance of the short-circuit location recorded by photograph or other means .....	See ID 07	—
	The pressing was stopped - When a voltage drop of 50 mV was detected; or		N/A
	- The pressing force of 800 N (cylindrical cells) or 400 N (prismatic cells) was reached		P
	Results: no fire, no explosion .....	See Table 7.3.2	P
<b>7.3.3</b>	<b>Propagation test (battery system)</b>		N/A
	Method to create a thermal runaway in one cell ... :		N/A
	Results: No external fire from the battery system or no battery case rupture .....		N/A
<b>8</b>	<b>BATTERY SYSTEM SAFETY (CONSIDERING FUNCTIONAL SAFETY)</b>		<b>N/A</b>
<b>8.1</b>	<b>General requirements</b>		N/A
	Functional safety analysis for critical controls		N/A
	Conduct of a process hazard, risk assessment and mitigation of the battery system		N/A
<b>8.2</b>	<b>Battery management system (or battery management unit)</b>		N/A
8.2.1	Requirements for the BMS		N/A
	The safety integrity level (SIL) target of the BMS		N/A
	The charge control evaluated by tests in clauses 8.2.2 to 8.2.4		N/A
8.2.2	Overcharge control of voltage (battery system)		N/A
	The exceeded charging voltage applied to the whole battery system		N/A
	The exceeded charging voltage applied to only a part of the battery system, such as the cell(s)..... :		N/A
	Results: no fire, no explosion .....		N/A
	The BMS interrupted the overcharging before reaching 110% of the upper limit charging voltage		N/A
8.2.3	Overcharge control of current (battery system)		N/A

IEC 62619			
Clause	Requirement + Test	Result - Remark	Verdict
	Results: no fire, no explosion..... :		N/A
	The BMS detected the overcharging current and controlled the charging to a level below the maximum charging current		N/A
8.2.4	Overheating control (battery system)		N/A
	The cooling system, if provided, was disconnected		N/A
	Elevated temperature for charging, 5 °C above maximum operating temperature..... :		N/A
	Results: no fire, no explosion..... :		N/A
	The BMS detected the overheat temperature and terminated charging		N/A
	The battery system operated as designed during test		N/A
<b>9</b>	<b>INFORMATION FOR SAFETY</b>		<b>P</b>
	The cell manufacturer provides information about current, voltage and temperature limits of their products		P
	The battery system manufacturer provides information regarding how to mitigate hazards to equipment manufacturers or end-users.		N/A
<b>10</b>	<b>MARKING AND DESIGNATION (REFER TO CLAUSE 5 OF IEC 62620)</b>		<b>P</b>
	The marking items shown in Table 1 in IEC 62620 indicated on the cell, battery system or instruction manual.		P
	Cell or battery system has clear and durable markings		P
	Cell designation		P
	Battery designation		N/A
	Battery structure formulation		N/A

IEC 62619			
Clause	Requirement + Test	Result - Remark	Verdict

<b>ANNEX A</b>	<b>OPERATING REGION OF CELLS FOR SAFE USE</b>	<b>P</b>
A.1	General	P
A.2	Charging conditions for safe use	P
A.3	Consideration on charging voltage	P
A.4	Consideration on temperature	P
A.5	High temperature range	P
A.6	Low temperature range	P
A.7	Discharging conditions for safe use	P
A.8	Example of operating region	P

<b>ANNEX B</b>	<b>PROCEDURE OF 7.3.3 PROPAGATION TEST</b>	<b>N/A</b>
B.1	General	N/A
B.2	Test conditions:	N/A
	– The battery fully charged according to the manufacturer recommended conditions .....	—
	– Target cell forced into thermal runaway .....	—
	– A specially prepared sample (e.g. a heater or a hole for nail penetration provided) used for ease of testing.....	—
B.3	Method used for initiating the thermal runaway. 1) Heater (Heater, Burner, Laser, Inductive heating 2) Overcharge 3) Nail penetration of the cell 4) Combination of above methods 5) Other methods.....	—

<b>ANNEX C</b>	<b>PACKAGING</b>	<b>P</b>
	The materials and pack design chosen in such a way as to prevent the development of unintentional electrical conduction, corrosion of the terminals and ingress of environmental contaminants	P

IEC 62619			
Clause	Requirement + Test	Result - Remark	Verdict

5.1	TABLE: Critical components information					P
Object/part no.	Manufacturer/ trademark	Type/model	Technical data	Standard	Mark(s) of conformity <sup>1)</sup>	
1. Cell	HE FEI GUOXUAN HIGH-TECH POWER ENERGY CO.,Ltd.	IFP20100140A- 27Ah	3.2V,27Ah	--	--	
1.1 Cell Case	--	--	Aluminium alloy	--	--	
1.2 Positive Electrode	--	--	LiFePO4, SP, GNC, PVDF	--	--	
1.3 Negative Electrode	--	--	Graphite, SP, CMC, SBR	--	--	
1.4 Separator	SEMCORP	PE	14um	--	--	
1.5 Electrolyte	--	--	LiPF <sub>6</sub> dissolved in organic solvent (EC+ PC+EMC+VC)	--	--	
2. Plastic materials	Interchangeable	Interchangeable	V-0, minimum 4mm	UL 94, UL 746C	UL	
<b>Supplementary information: N/A</b>						
<b><sup>1)</sup> Provided evidence ensures the agreed level of compliance. See OD-2039.</b>						

IEC 62619			
Clause	Requirement + Test	Result - Remark	Verdict

7.2.1	TABLE: External short-circuit test (cell or cell block)					P
Sample No.	Ambient (at 25°C ± 5°C)	OCV at start of test (V dc)	Resistance of Circuit (mΩ)	Maximum Case Temperature Rise ΔT (°C)	Results	
F10030	24.6	3.51	28.1	44.1	A,E	
<b>Supplementary information:</b> A - No fire or Explosion B - Fire C - Explosion D - The test was completed after 6 h E - The test was completed after the cell casing cooled to 20% of the maximum temperature rise F - Other (Please explain):___						

IEC 62619			
Clause	Requirement + Test	Result - Remark	Verdict

7.2.5	TABLE: Overcharge test (cell or cell block)					P
Sample No.	OCV at start of test (V dc)	OCV at end of test (V dc)	Measured Maximum Charging Current (A)	Measured Maximum Charging Voltage (V dc)	Max. Cell Case Temperature, (°C)	Results
F10034	2.96	3.89	54	5	53.0	A,E
<b>Supplementary information:</b> Results: A - No fire or Explosion B - Fire C - Explosion D - Test concluded when temperature reached a steady state condition E - Test concluded when temperature returned to ambient F - Other (Please explain): _____						

7.2.6	TABLE: Forced discharge test (cell or cell block)				P
Sample No.	OCV before applying reverse charge, (V dc)	Target Voltage (V dc)	Measured Reverse Charge Current It, (A)	Total Time for Reversed Charge Application (min)	Results
Z00120	2.33	-3.85	27	90	A
<b>Supplementary information:</b> Results: A - No fire or Explosion B - Fire C - Explosion D - Other (Please explain): ____					

IEC 62619			
Clause	Requirement + Test	Result - Remark	Verdict

7.3.2	TABLE: Internal short-circuit test (cell)				P
Sample No.	OCV at start of test, (V dc)	Particle location <sup>1)</sup>	Maximum applied pressure, (N)	Results	
I19819	3.50	1	400	A,D	
I19820	3.50	1	400	A,D	
I19821	3.51	1	400	A,D	
I19822	3.50	1	400	A,D	
I19823	3.49	1	400	A,D	

**Supplementary information:**  
<sup>1)</sup> Identify one of the following:  
1: Nickel particle inserted between positive and negative (active material) coated area.  
2: Nickel particle inserted between positive aluminium foil and negative active material coated area.

**Results:**  
A - No fire or explosion  
B - Fire  
C - Explosion  
D - Test concluded when 50 mV voltage drop occurred prior to reaching force limit  
E - Test concluded when 800/400 N pressure was reached and 50 mV voltage drop was not achieved  
F - Test was concluded when fire or explosion occurred  
G - Other (Please explain): \_\_\_



IEC 62619			
Clause	Requirement + Test	Result - Remark	Verdict

7.3.3	TABLE: Propagation test (battery system)					N/A
Sample No.	OCV of Battery System Before Test, (V dc)	OCV of Target Cell Before Test, (V dc)	Maximum Cell Case Temperature, (°C)	Maximum DUT Enclosure Temperature, (°C)	Results	
Method of cell failure <sup>1)</sup>		Location of target cell		Area for fire protection (m <sup>2</sup> )		
<b>Supplementary information:</b>						
<p>1) Cell can be failed through applied heat, overcharge, nail penetration or combinations of these failures or other acceptable methods. See supporting documentation for details on cell failure method</p> <p>2) If the battery system has no outer covering, the manufacturer is required to specify the area for fire protection.</p> <p>Results:</p> <p>A – No fire external to DUT enclosure or area for fire protection or no battery case rupture</p> <p>B – Fire external to DUT enclosure or area for fire protection</p> <p>C – Explosion</p> <p>D – Battery case rupture</p> <p>E - Other (Please explain): ___</p>						

IEC 62619			
Clause	Requirement + Test	Result - Remark	Verdict

8.2.2	TABLE: Overcharge control of voltage (battery system)				N/A
Sample No.	OCV at start of test for Cell/Cell Blocks, (V dc)	Maximum Charging Current, (A)	Max. Charging Voltage, (V dc)	Max. Voltage of Cell/Cell Blocks, (V dc)	Results
			<b>Charge Voltage Applied Battery System: 1)</b>		
			<b>Whole</b>	<b>Part</b>	
<p><b>Supplementary information:</b></p> <p>1. The exceeded voltage can be applied to only a part of the system such as the cell(s) in the battery system per Figure 6 of IEC 62619, if it is difficult to do it in using the whole battery system.</p> <p>Results:</p> <p>A - No Fire or Explosion            B - Fire            C - Explosion            D - The voltage of the measured cells or cell blocks did not exceed the upper limit charging voltage            E - The voltage of the measured cells or cell blocks did exceed the upper limit charging voltage            F - All function of battery system did operate as intended during the test.            G - All function of battery system did not operate as intended during the test.            H - Other (Please explain): ____</p>					

8.2.3	TABLE: Overcharge control of current (battery system)			N/A
Sample No.	OCV at start of test, (V dc)	Max. Charging Current, (A)	Max. Charging Voltage, (V dc)	Results
<p><b>Supplementary information:</b></p> <p>Results:</p> <p>A - No fire or Explosion            B - Fire            C - Explosion            D - Overcurrent sensing function of BMU did operate and then charging stopped            E - Overcurrent sensing function of BMU did not operate and then charging stopped            F - All function of battery system did operate as intended during the test.            G - All function of battery system did not operate as intended during the test.            H - Other (Please explain): ____</p>				

IEC 62619			
Clause	Requirement + Test	Result - Remark	Verdict

8.2.4	TABLE: Overheating control (battery system)			N/A
Model No.	OCV at start(SOC 50%) of test, V dc	Maximum Charging Current, A	Maximum Charging Voltage, V dc	
Maximum Specified Temperature of Battery System, °C	Maximum Measured Cell Case Temperature, °C		Results	
<b>Supplementary information:</b> Results: A – No fire or Explosion B – Fire C – Explosion D - Temperature sensing function of BMU did operate and then charging stopped E - Temperature sensing function of BMU did not operate and then charging stopped F - All function of battery system did operate as intended during the test. G - All function of battery system did not operate as intended during the test. H - Other (Please explain): _____				

**ENCLOSURE**

Supplement ID	Description
01-01	Front view
01-02	Back view
01-03	Top view
02	Specification
03	Outline Dimension
04	Manufacturer date code
05	Package requirement
06	IATF 16949 Certification for manufacturer
07	The location of Nickel particle in the Internal short-circuit test

ID 01-01



ID 01-02



ID 01-03



## ID 02

Item	Specification
Product name	lithium ion cell
Type/model	IFP20100140A-27Ah
Nominal voltage	3.2V
Rated capacity	27Ah
Charging voltage declared by manufacturer	3.65V
Maximum charging voltage	3.9V
Upper limit charging voltage	3.85V
Charging current declared by manufacturer	27A
Maximum Charging Current	54A
End of Charging Current	1.35A
Standard charging temperature range	-10~55°C
Discharge Cut-Off Voltage	2.0V
Dimensions	20.5mm x 100mm x 140.5mm
Weight	611±5g
0.2 It A discharging current	27A
Maximum discharging current	67.5A
Discharge operating temperature	-30~60°C
Storage temperature	-10~30°C



ID 03

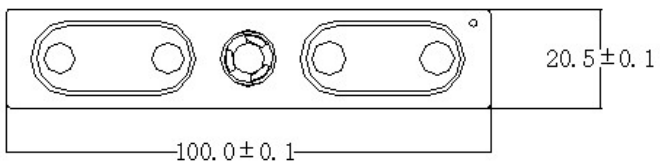
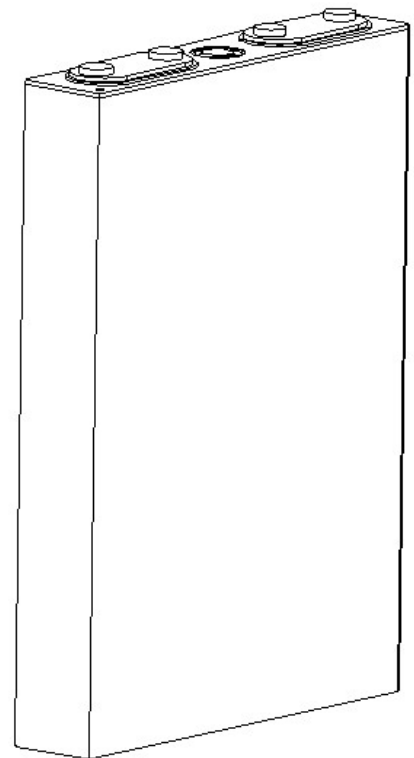
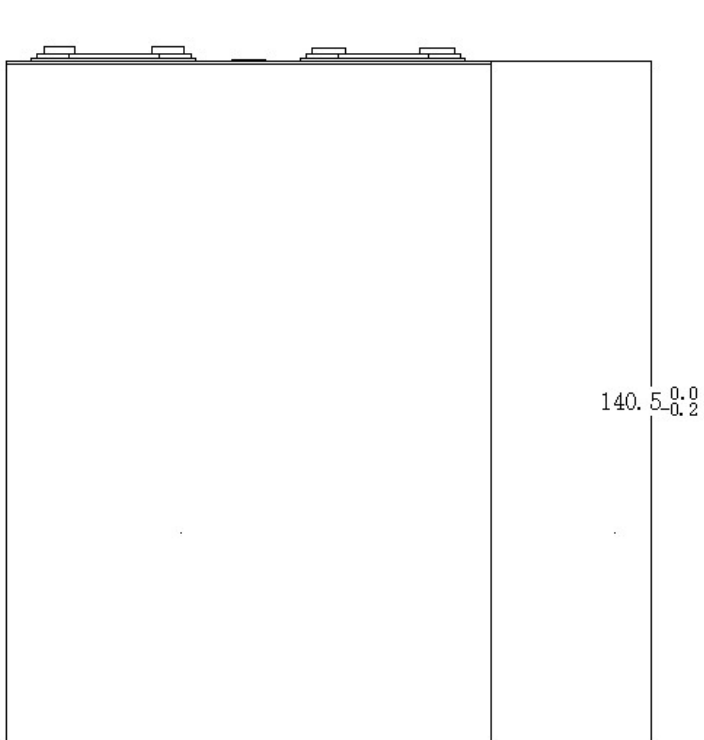

ID 04

Date Code:

YYM:

YY: Year of production, total 2 digits, 18 means 2018...

M: Month of production, 1 letter from A to L, A means January,  
B means February...

ID 05

1、 cell

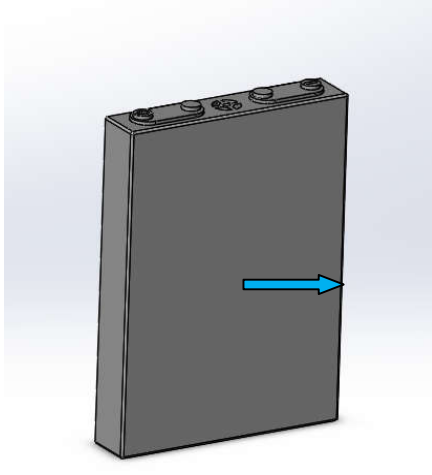

2、 pack

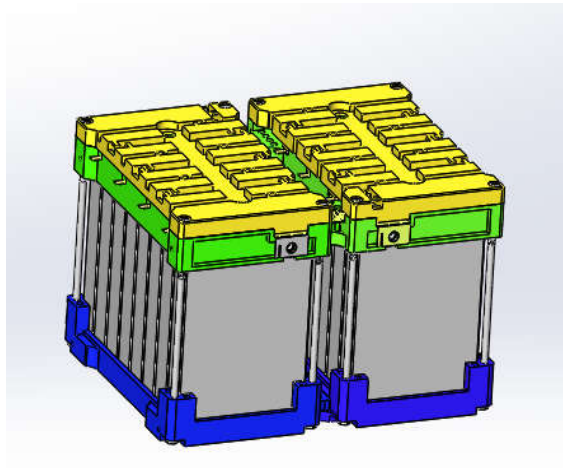

3、 Shipping package

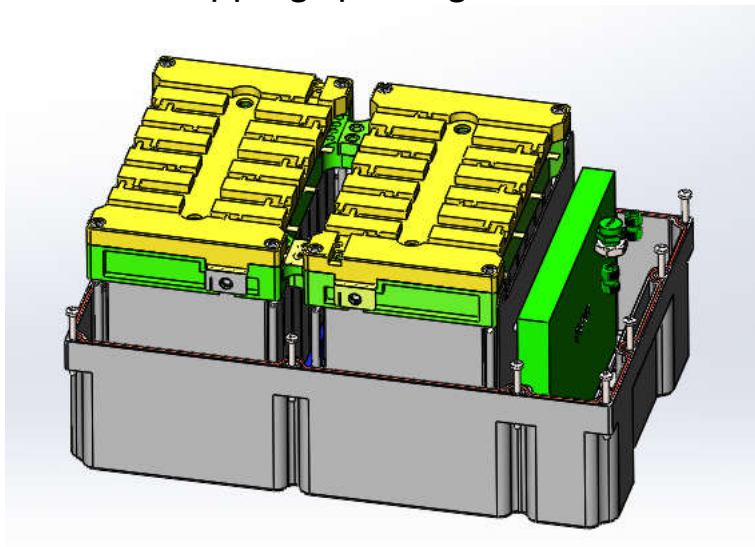

ID 06

# CERTIFICATE

The Certification Body  
of TÜV SÜD Management Service GmbH  
certifies that

**Hefei Guoxuan High-tech Power Energy Co., Ltd.**  
No. 599, Daihe Road, Xinzhan District,  
Hefei City, Anhui Province, P. R. China  
Post Code: 230012

has established and applies  
a Quality Management System for

**Development and Manufacturing of  
Lithium-ion Battery for Electric Vehicle**  
(with Product Design as per Chapter 8.3).

An audit was performed and has furnished proof  
that the requirements according to

**IATF 16949**  
First Edition 2016-10-01

are fulfilled.

Issue date: 2017-07-11  
Expiry date: 2020-07-10

Certificate Registration No.: 12 111 41110 TMS  
IATF Certificate No.: 0269131



Product Compliance Management  
Munich, 2017-07-11

Page 1 of 1

TÜV SÜD Management Service GmbH • Zertifizierungsstelle • Ridlerstraße 65 • 80339 München • Germany  
[www.tuev-sued.de/certificate-validity-check](http://www.tuev-sued.de/certificate-validity-check)

ZERTIFIKAT ■ CERTIFICATE ■ CERTIFICADO ■ CERTIFICAT

ZERTIFIKAT ■ CERTIFICATE ■ CERTIFICADO ■ CERTIFICAT

證書證書 ■ CERTIFICATE ■ CERTIFICADO ■ CERTIFICAT

ZERTIFIKAT ■ CERTIFICATE ■ CERTIFICADO ■ CERTIFICAT

ID 07

